

# Trim Trail Package E



**INSPIRE PLAY**

Adventure fitness trails or trim trails are a great way to get the kids active. They make a great addition to school playing fields and can include a range of activities that help develop balance, hand-eye coordination and physical strength. We can also include activity trails as part of a complete playground scheme providing extra activities without exceeding your budget.

The difficulty level of fitness trail equipment can be tailored to different age groups. We recommend that fitness/activity trails for younger children consist of balancing and coordination activities. Juniors (KS2 & KS3) will get more enjoyment from physical challenges like our A Frame Cargo nets and climbers.

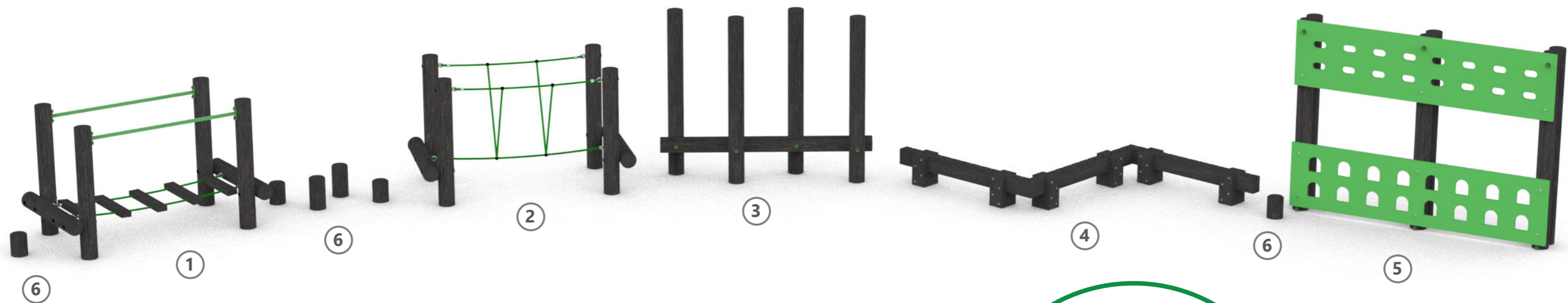

Plan View

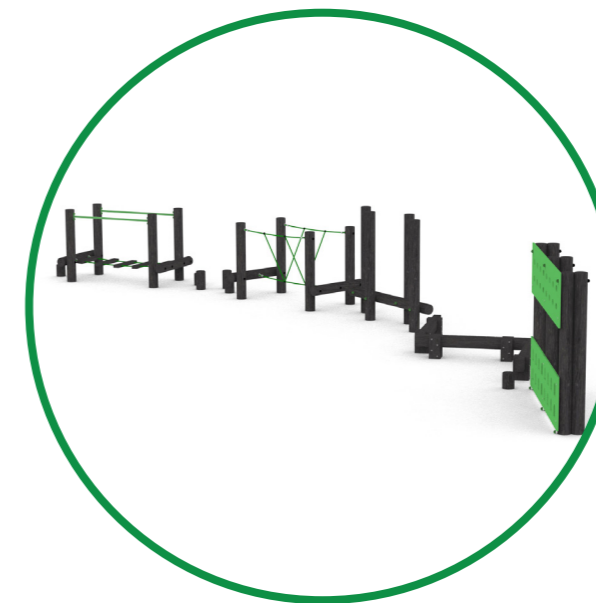
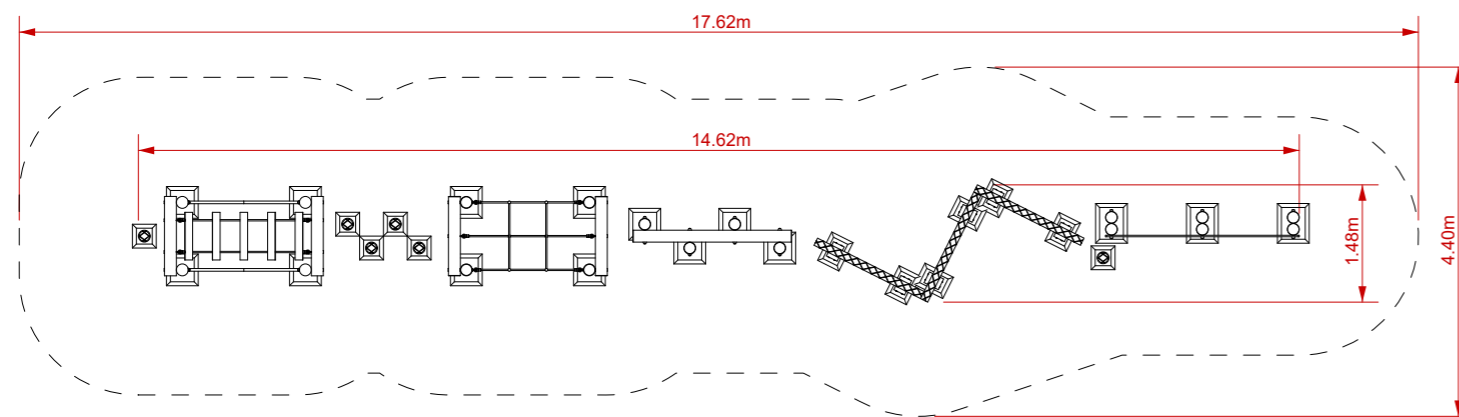

Trim Trail Items:

1. Clatter Bridge
2. V Rope Bridge
3. Balance Weave
4. Zig Zag Balance Beams
5. Double Traverse Wall
6. Stepping stones (set of Six)

**Product Specification:**

**Dimensions:** L: 14.62m W: 1.48m H: 1.80m  
**Age Range:** 5+ years  
**Play Type:** Active  
**Free Fall Height:** 0.60m  
**Free Space Required:** L: 17.62mm W: 4.40m

**Safety Surfacing Area:** 62.7m<sup>2</sup>  
**Assembly:** Installation Required  
**Mass of Heaviest Part:** kg  
**Dimensions of Largest Part:** L: 2.40m W: 0.15m  
**Conformity to EN1176:** Yes



**INSPIRE PLAY**

Units 10 & 11  
 Stonegravels Lane  
 Chesterfield  
 S41 7LF

T: 01832 275902  
 E: sales@inspireplay.co.uk  
 www.inspireplay.co.uk